TELEMATIKK

Theses at Department of Telematics Spring 2012 (v3 12.12.2011)

The thesis proposals are classified due to which main profile they belong to.

These terms are used:

- NT = **N**ett og **T**jenestekvalitet (Networks and Quality of Service)
- TS = **T**jenester og **S**ystemutvikling (Services and System Engineering)
- IS = **I**nformasjons**S**ikkerhet (Information Security)
- TØ = **T**ele**Ø**konomi (Tele-economics)
- TSA = **T**elematikk og **S**Amfunn (Telematics and society)

Some of the proposals are related to several main profiles.

The students can choose the topics they want as long as they have the proper scientific basis. Consult a professor if there are any doubts.

Please choose at least 5 topics in preferred order dispersed on several professors by registering name, e-mail address and topic numbers.

The Department will allocate the topics on a fair basis. We seek to distribute the responsibility of supervision equally among the professors. If conflicts occur, we have the opportunity to use a variety of methods to solve it. Drawing lots may be one way to go. Grades are not criteria for allocation. Empirically most students get one of their 3 top-most priorities.

Time schedule:

15 December:

Deadline for registration of wishes for thesis

Week 51:

The Department coordinates the choices and informs the students about the allocation.

By 16 January:

Register basic information about the thesis in DAIM, and submit master's thesis contract to Mona Nordaune, room B-213.

Topics from IDE portalen: <http://www.ideportalen.no/>

If you find an interesting topic here, please contact the Department of Telematics before you approach the company offering the topic.

1. (IS) The peculiar use of hash functions for digital evidence integrity

Judicial verdict must be founded on evidence. It has become standard routine for law enforcement to seize and extract digital evidence from electronic devices and networks. The digital evidence authenticity (provenance and integrity) are important properties assured by the investigators' chain-of-custody routines. Currently, there seems to be an awkward practice of using one-way hash functions for this purpose. The goal of this assignment is to make a critical review of this practice, and to explore and propose alternative solutions that are satisfactory in the standard model of cryptographic evidence.

Supervisors: Danilo Gligoroski (danilog@item.ntnu.no) Svein Willassen (svein@willassen.no)

Professor: Stig Frode Mjøl̄snes (stig.mjolsnes@item.ntnu.no)

2. (IS) Secure Key Generation and Distribution for VPN.

A Virtual Private Network (VPN) connection can provide remote offices and mobile terminals secure access and end-to-end communication to the organization's home network and services. The stored data on a mobile terminal (e.g. laptop or mobile) can be secured by low-level hard disk encryption, where the cryptokey for this protection is stored and processed by a separate small device, e.g. USB memory stick. The temporary crypto-key for the VPN association can be generated offline by a stationary key generator unit at the company's home-base (HQ). This CR-generator may in the same operation produce a PIN-code for the current crypto-key, and an Emergency Destruction Code for the subject key.

This project will explore the possible solutions that can combine and integrate the VPN communication with stored data protection in an efficient and transparent way.

Experimental setups should be done to demonstrate the feasibility of the proposed solution.

Supervisor: Nils M. Aune, Noiseless AS (nils@noiseless.no)

Professor: Stig Frode Mjøl̄snes (stig.mjolsnes@item.ntnu.no)

3. (IS) Security Analysis of the LTE Authentication and Key Agreement Protocol

The next generations of mobile systems that are built and deployed now are labelled "Long Term Evolution" and "Evolved Packet System" because the networks are all IP packet based. The aim of this master's thesis will be to analyze the security of the 3G UMTS and LTE authentication and key agreement protocols. The protocol specifications can be found in the 3GPP standards, and elsewhere.

The student will perform the analysis using the automatic cryptographic protocol prover CryptoVerif. This tool works in the model of modern cryptography and its proofs are similar to the manual proofs of a cryptographer, i.e., CryptoVerif's proofs are sequences of games. CryptoVerif is able to

prove secrecy and authentication properties of protocols with a high degree of automation. The student should have a good knowledge of cryptography.

Some related work can be found at <http://arxiv.org/abs/1109.2066>

*Supervisors: Postdoc Joe-Kay Tsay (joe.k.tsay@item.ntnu.no) and Stig F. Mjølunes
Professor: Stig F. Mjølunes (stig.mjolsnes@item.ntnu.no)*

4. (IS) Metrics for information security - incident response

A main goal with information security is to prevent incidents from happening, and if they still occur, reducing the consequences as much as possible. A number of countermeasures are usually implemented, and it is a continuous process to consider new threats and appropriate measures. The choices are often based on risk assessments and good practice. However, it is not trivial to prove which measures are the most efficient.

In this exercise the student will survey existing metrics, including indicators and methods for measuring, within information security incident response, and identify potential for improvements to existing schemes.

Veileder: Maria B. Line (maria.b.line@item.ntnu.no)

Faglærer: Svein Knapskog (svein.johan.knapskog@item.ntnu.no)

5. (IS) Android Apps and Permissions: Security and Privacy Risks

(This project is opened to 1 or 2 students)

Third-party applications drive the attractiveness of web and mobile application platforms. Many platforms (incl. Android, HTML5 web apps, Facebook) rely on granular permissions to avoid granting full privileges to third party applications. The case of Android OS is particularly interesting. However, the permission system on Android is complex. There are more than 135 official permissions, and it has been a challenge in communicating the actual scope of each permission to both the developers and users. This creates rooms for exploitations; malicious applications (or grayware) disguise themselves amongst the hundreds of thousands of normal ones.

This project will focus on a large scale data collection and analysis to measure and characterize the behaviors of bad applications. The basic ideas (adaptable to student's interests) would be as follows:

1. build an automated and long term data collection process (e.g., using Bash/Python)
2. parse and organize the information obtained into structured database (e.g., using MySQL)
3. analyze the data and visualize interesting patterns (e.g., using R)
4. characterize the behaviors of bad apps (e.g., detecting anomalous permission requests)

Knowledge on scripting languages and MySQL would be helpful. On the other hand, a running set of tools has been implemented by the supervisor and can be passed on to the student (for improvement

and adjustment) readily.

Related literature include:

1. <http://www.cs.berkeley.edu/~afelt/felt-permissions-webapps11.pdf>
2. <http://www.ccs1.carleton.ca/~dbarrera/files/ccs10-barrera.pdf>

Feel free to come to Room E-218 / ping the supervisor for discussion.

Supervisor: Pern Hui Chia (chia@q2s.ntnu.no, <http://www.q2s.ntnu.no/people/chia/>)

Professor: Svein Knapskog (svein.johan.knapskog@item.ntnu.no)

Common header for the next 5 topics

About Norman ASA

Norman ASA, founded in Oslo Norway in 1984, is a world leader and pioneer in proactive content security solutions and forensics malware tools. Millions of users rely on Norman's solutions, such as network security, endpoint protection solutions and malware analysis tools, to protect their values. Norman, as a technology supplier, offers proactive antimalware technology to be used within security products and service security solutions worldwide. Norman's proactive antimalware solutions are powered by the patented technology, Norman SandBox®.

Through its technology platform, Norman delivers core antimalware protection for clients, servers and network security. These products and services are designed to protect business communications and resources, including corporate networks and applications, remote employees, branch offices, and extranets. The company also offers market-leading advanced malware analyzers which enable organizations to automate the process of analyzing suspicious files, identifying types of malware, and assessing threats. Norman's award-winning security solutions protect millions of consumer PCs from hackers, spyware and identity theft.

Norman ASA, Strandveien 37, 1324 Lysaker, Norway

6. (IS / TS / NT) Scaling of cloud services

Description: More and more front-facing services are moved "into the cloud" for improved accessibility and easier maintenance. The goal of this project is to find out how to set up a cloud infrastructure that can handle any number of clients worldwide that will:

- a) Gather telemetry data from the clients
- b) Do massive amounts of lookups against the cloud

This project is an exercise both in horizontally scaling large systems, and how to use existing cloud infrastructure for this purpose.

This assignment is open for 1 student.

The project work can be conducted both on-site at Norman ASA or off-site. Regular meetings and/or conference calls are planned to support the student.

This research project will be conducted in cooperation with the anti-virus and forensic tools vendor Norman ASA in Lysaker, Oslo. Guidance and insights are provided from a professional Research and Development (R&D) point of view.

Supervisor: XX at Norman

Professor: Yuming Jiang (jiang@item.ntnu.no)

7. (IS / NT) URL Crawling & classification system

Description: Malware is commonly hosted on hacked websites or temporary malicious servers. The two-fold goal of this project is to:

- a) Create a system to harvest potentially malicious URL's by crawling the web
- b) Create a system to give each URL a reputation-score and classify it as malicious or not without blacklisting clean sites

References:

- Throwing a MonkeyWrench into Web Attackers Plans, Buescher et al., Communications and Multimedia Security 2010
- Automating Malware Scanning Using Workflows, Stirling et al., CCGrid 2009

This assignment is open for 1 student.

The project work can be conducted both on-site at Norman ASA or off-site. Regular meetings and/or conference calls are planned to support the student.

This research project will be conducted in cooperation with the anti-virus and forensic tools vendor Norman ASA in Lysaker, Oslo. Guidance and insights are provided from a professional Research and Development (R&D) point of view.

Supervisor: XX at Norman

Professor: Svein Knapskog knapskog@q2s.ntnu.no

8. (IS) Automatic signature creation for speeding up the fight against malware

Every day tens to hundreds of thousands of new malicious files are found in the wild. Not every file is a new threat but often just a self-defending variant of an existing one. The best signatures for detecting families of threats are usually created by humans. Unfortunately, there are not enough people around to target this growing amount. The brute-force approach to create the best automated signatures is NP-hard and thus practically infeasible to apply to the growing problem.

This assignment requires a student with practical out-of-the-box thinking. The goal is to evaluate the existing approximations and heuristics for creating anti-virus signatures and to derive a practical solution to the problem. This requires to exploit (immanent) weaknesses of malware variants. A battle of good vs. evil.

References:

- <http://blog.zynamics.com/2010/02/17/automating-av-signature-generation/>

- Polygraph: Automatically Generating Signatures for Polymorphic Worms, Newsome et al., IEEE S&P 2005

This assignment is open for 1-2 students

The project work can be conducted both on-site at Norman ASA or off-site. Regular meetings and/or conference calls are planned to support the student.

This research project will be conducted in cooperation with the anti-virus and forensic tools vendor Norman ASA in Lysaker, Oslo. Guidance and insights are provided from a professional Research and Development (R&D) point of view.

Supervisor: XX at Norman

Professor: Svein Knapskog knapskog@q2s.ntnu.no

9. (IS) Cleaning up after Malware

With the amount of new malware coming out every day many users are getting infected. Most AV products claim that they can clean a system after a system has been infected. Is that true? and how good to they clean up? The goal with this task is to build up a framework that can be used to verify that we clean up all malicious traces on an infected system. The system should be fully automated and scalable.

This assignment is open for 1 student.

The project work can be conducted both on-site at Norman ASA or off-site. Regular meetings and/or conference calls are planned to support the student.

This research project will be conducted in cooperation with the anti-virus and forensic tools vendor Norman ASA in Lysaker, Oslo. Guidance and insights are provided from a professional Research and Development (R&D) point of view.

Supervisor: XX at Norman

Professor: Øivind Kure (okure@item.ntnu.no)

10. (IS / TS) Detection methodology study

As the number of new unique malware-samples seen every day continue to rise, finding new efficient ways to detect these with as little effort as possible is getting more and more important. The purpose of this study is to find new innovative ways to generically detect large clusters of samples with varying similarities, with as little impact as possible on the system it is running on.

The candidate needs a genuine interest in low level programming and statistical analysis.

References:

- <http://www.clamav.net/doc/latest/signatures.pdf>
- The Art of Computer Virus Research and Defense, Szor, Addison-Wesley, 2005

This assignment is open for 1 student.

The project work can be conducted both on-site at Norman ASA or off-site. Regular meetings and/or conference calls are planned to support the student.

This research project will be conducted in cooperation with the anti-virus and forensic tools vendor Norman ASA in Lysaker, Oslo. Guidance and insights are provided from a professional Research and Development (R&D) point of view.

Supervisor: XX at Norman

Professor: Yuming Jiang jiang@item.ntnu.no

11. (TØ,NT) Business opportunities by exploiting 3rd party cookies

3rd party cookies enable websites to track and record user behaviour. Users are often unaware of this situation, resulting in huge logged information about users that may be exploited for e.g. marketing purposes. However, the logging of such information also raises privacy issues. In this assignment the student will look into the use of 3rd party cookies and how it can be exploited for future business opportunities.

In particular, the student will study the following:

- A background study on cookies
- How cookies can be utilized for business purposes
- Tele-economic aspects of the use of cookies
- Case study of marketing businesses utilizing cookies

This assignment is open for 1 student only.

Professor: Harald Øverby (haraldov@item.ntnu.no)

12. (TØ,TS). Economics in the networked computer game industry

The networked computer game industry has experienced a huge increase in active players and income during the last decade. The emergence of online-multiplayer games such as World of Warcraft and Counter-strike, as well as casual games on facebook etc has huge impacts on the value chain in the industry. In this assignment, the student will look into the economics of networked computer games, from a technologically point of view.

In particular, the student may study the following topics:

- The economics of small and peer-produced games, and the role of peer-production in game development
- Modelling the computer game market

This assignment is open for 1 student only.

Professor: Harald Øverby (haraldov@item.ntnu.no)

13. (TØ,NT). Modelling Tele-economics systems using Business Dynamics

Business dynamics is a well established framework for analyzing feedback and relationships between actors in business environments. In this assignment, the student will use business dynamics to model tele-economic systems. Systems modeled can be e.g. scenarios from the FTTH industry, mobile telephone, VoIP. In particular, the student will study the following:

- A background study of business dynamics
- Identify business scenarios in the telecommunication industry
- Model the identified scenarios using business dynamics

This assignment is open for 1 student.

Professor: Harald Øverby (haraldov@item.ntnu.no)

14. (TØ). The long tail principle

The long tail principle has changed the way business has been done in several industries. As the marginal cost of providing e-products is close to 0, less popular content can also be provided to consumers, without reduced profit. This assignment will look into the long-tail principle. An analytical model estimating the income for different product groups should be developed.

In particular, the student will study the following:

- Background study on the long tail principle
- Develop analytical models describing the long tail principle
- Analyze business cases within the long tail industry

This assignment is open for 1 student only.

Professor: Harald Øverby (haraldov@item.ntnu.no)

15. (TØ,NT). Network externalities in Telecom markets

Network externalities refers to the fact that a certain product has value on other users of the same product. There are a number of network externalities in telecom markets, which totals into an aggregated network effect. In this assignment, the student will look into network effects and the underlying processes influencing the aggregated network effect. In particular, the student will study the following:

- Background study on network externalities
- Identify network externalities in Telecom markets
- Quantify the aggregated network effect

This assignment is open for 1 student.

Professor: Harald Øverby (haraldov@item.ntnu.no)

16. (TØ,NT). Social Return on Investment (SROI) analysis for FTTH in Norway

In recent years, huge investments have been made in constructing Fibre-To-The-Home (FTTH) networks in Norway. However, due to the high cost of installing FTTH, the question of financial profitability of these investments has been raised. Social Return on Investment (SROI) analysis offers a tool to calculate the overall social value of an investment, such as FTTH roll-out. In this assignment the student shall use SROI to analyze the Norwegian FTTH investments made during the last years, evaluating their profitability.

This assignment is open for 1 student only.

Professor: Harald Øverby (haraldov@item.ntnu.no)

17. (TØ,NT). Cost analysis of optical packet switch architectures

Optical Packet Switching (OPS) is a candidate for the future core- and metro network. OPS relies in the optical packet switch for operation, which may be realized using a huge variety of design choices. In this assignment, the student will look into optical packets switch design, and focus on cost and complexity issues of the chosen optical packet switch design architecture.

This assignment is open for 1 student only.

Professor: Harald Øverby (haraldov@item.ntnu.no)

18. (TØ,NT). Economic analysis of QoS differentiation in OPS networks

Quality of Service (QoS) differentiation is needed in order to support services demanding high QoS as well as to optimize resource usage in networks. In this project the student will look into the economic aspects of QoS differentiation in Optical Packet Switched networks (OPS). The cost of introducing QoS differentiation in OPS should be studied as well as the required added revenue needed to compensate for the potential increased cost.

In particular, the student will study the following:

- Background study in OPS technology
- Background study in QoS differentiation
- Developing analytical/simulation models describing the cost of introducing QoS differentiation in OPS

This assignment is open for 1 student.

Professor: Harald Øverby (haraldov@item.ntnu.no)

19. (TØ,NT) Incentives in Location-Aware Peer-to-Peer Networks: A Game-Theoretical View

Peer-to-peer applications make up a large portion of Internet traffic . Location-aware peer-to-peer (p2p) network mechanisms have been proposed to provide users with better download performance and Internet Service Providers (ISPs) with better control over actual traffic flowing through their networks. Different solutions have been published and deployed to achieve these goals with varying degrees of success. In this assignment, the student will look into which strategies provide actual economic incentives for ISPs and users in order to reach widespread deployment. The student will use the toolset of game theory to model and analyse existing location-aware p2p network mechanisms.

In particular, the student will study the following:

- Background study on location-aware p2p network mechanisms.
- Game theoretical modeling and analysis of location-aware p2p network mechanisms with regard to incentives for providers and users.

This assignment is open for 1 student.

The assignment can be continued in the master thesis.

Supervisors: Gergely Biczók (gbiczok@item.ntnu.no)

Professor: Harald Øverby (haraldov@item.ntnu.no)

20. (NT) Green Telecom and lowered cost through power-optimized transport/metro networks

Both because of the green telecom trend and the general demands for lowering power consumption in telecom equipment, there is a need for optimizing network designs with respect to lowered power-consumption. There is also an increasing focus on the benefit of the lowered operational cost achieved through lowered power consumption. Availability of electricity depends on the infrastructure of a country. A general rule of thumb may be that heavy processing should be performed where access to renewable electrical power sources is high. The project will explore the effect of optimizing the load-balance and the processing in the network with respect to power-consumption. Generally, processing in the network should be minimized through using e.g. optical bypassing nodes. Furthermore, processing at sites with poor and hence expensive access to electricity should be minimized, moving heavy traffic processing to sites with high and cheaper electricity availability. Electricity availability may experience time-of-day variations. Hence network load-balancing mechanisms may act accordingly. The parameters involved in enabling a green telecom transport/metro network shall be outlined. Reduction in power-consumption and optimization on power-consumption cost shall be analyzed and quantified. Analysis may be performed using e.g. simulation-techniques. Techniques for controlling the network, like e.g. extensions to routing protocols may be explored further in the master-project.

The Master project will be tutored by:

Steinar Bjørnstad (ITEM/Transpacket) - Steinar.Bjornstad@item.ntnu.no, Phone: 90081033,
and/or

Harald Øverby (ITEM) – Haraldov@item.ntnu.no

21. (NT) Environmentally friendly and cost reduced transport/access network-nodes through power optimization

Both because of the green telecom trend and the general demands for lowering power consumption in telecom equipment, there is a need for optimizing network node designs with respect to lowered power-consumption. There is also an increased focus on the benefit of the lowered operational cost achieved through lowered power consumption. The project will explore the effect of different power-reduction techniques on a node-system level (not on a circuit level). Examples of techniques are e.g. reducing the nodes processing needs through avoiding processing of traffic transiting the node and reducing node interface power consumption through turning interfaces off during low-load/idle periods. Parameters impacting the power consumption of a node may be varied for characterizing what are the most important parameters for reducing power in nodes and networks. The reduction in node power-consumption shall be quantified relatively and its implication on total power consumption for a complete network shall be outlined.

The Master project will be tutored by:

Steinar Bjørnstad (ITEM/ Transpacket) - Steinar.Bjornstad@item.ntnu.no, Phone: 90081033,

and/or
Harald Øverby (ITEM) – Haraldov@item.ntnu.no

22. (NT) Cost analysis comparing the OpMiGua hybrid network with pure packet and pure circuit switched networks

TransPacket is a startup-company targeting commercialisation of OpMiGua technology.

The “Optical Migration Capable Networks with Service Guarantees” (OpMiGua) concept (<http://www.opmigua.com>) has the main objective of combining the best properties from both circuit and packet switched networks into a hybrid solution. A number of studies show that the performance properties of the OpMiGua network are found attractive. However, number of studies addressing the cost-efficiency of the network is limited. In this project, the student will analyze the cost of a network utilizing a TransPacket OpMiGua node and compare this with pure circuit and a pure packet switched network costs.

The Master project will be tutored by:

Steinar Bjørnstad (ITEM/Transpacket) - Steinar.Bjornstad@item.ntnu.no, Phone: 90081033,

and/or
Harald Øverby (ITEM) – Haraldov@item.ntnu.no

Co-supervisor will be: Raimena Veisllari - veisllar@item.ntnu.no

23. (NT) Quality of Service (QoS) in optical networks: Requirements of future applications

Moving from circuit switched to packet switched networks, Quality of Service (QoS) is an important topic. A number of mechanisms exist for packet switched networks for enabling the networks to support demanding applications. Typically, performance parameters like packet loss ratio, packet delay and packet delay variation are measures that should be optimized according to the applications demands. In circuit switched networks, packet loss and packet delay variation may be zero, and

packet delay very low. It is however very demanding (if possible) to offer a QoS as good as in a circuit switched network, through a packet switched network. An important question to rise is if such a high QoS is really needed and how high QoS that is needed for current and future applications that shall be serviced by the network.

In the project the student shall analyze the QoS performance needs of different applications and services like e.g. future mobile backhaul services, future TV like e.g. 3D-TV, future/current online-gaming etc. Both the needs of current applications and possible future applications shall be analyzed. A special attention may be given to tolerance to delay and packet delay variation.

The Master project will be tutored by:

Steinar Bjørnstad (ITEM/Transpacket) - Steinar.Bjornstad@item.ntnu.no, Phone: 90081033,

Co-supervisor will be: Raimena Veisllari - veisllar@item.ntnu.no

24. (NT) Operation and management (OAM) in Ethernet and MPLS-TP packet based networks

Migrating from the reliable high performance SDH network to a fully packet based network, puts high demands on the packet network. For fulfilling these demands, existing protocols are extended, trying to bring known functions in circuit switched systems like monitoring and traffic engineering into the packet switched network.

Recently, a number of extensions to existing protocols for transport networks have been proposed. Examples are the Transport Profile extension to MPLS: MPLS-TP, bringing OAM capability to MPLS. Similar features are brought into Ethernet: Link-OAM and Service-OAM. Furthermore, the OTN (Optical Transport Network) standard is proposed as a predecessor for SDH, enabling a physical layer transport protocol for optical networks. In the project, all protocols will be studied in detail and an overview will be given. Pros and cons of the different solutions shall then be evaluated. A part of the study may include a simulation analysis.

The Master project will be tutored by:

Steinar Bjørnstad (ITEM/Transpacket) - Steinar.Bjornstad@item.ntnu.no, Phone: 90081033,

Co-supervisor will be: Raimena Veisllari - veisllar@item.ntnu.no

25. (NT) OTN switching

The OTN (Optical Transport Network) standard is an ITU-T standard (G.709) describing a method for wrapping in signals of different protocol-formats for transport across an optical network. OTN is seen as a predecessor for SDH, enabling much of the same monitoring and management capabilities known from SDH. While the first versions of the OTN-standard describes transport at 2.5 and 10 Gb/s wavelength-channel bitrates, the standard has recently been extended to include bitrates up to 100 Gb/s and down to 1 Gb/s. Furthermore, while OTN originally where only described as a method for reliable data-transport, switching of sub-wavelength bitrates has recently proposed. This enables e.g. add/drop at the OTN layer of parts of e.g. a 100 Gb/s stream, enabling the use of 10 Gb/s interfaces on IP-routers in a 100 Gb/s transport network.

In the project, the student will study recent progress in OTN, including the OTN switching capabilities. Performance of a pure packet switched network shall be compared with the performance of a OTN switching based network. The performance comparison will typically be performed on a proposed network scenario. Performance may be found using analytical and/or simulation methods.

The Master project will be tutored by:

Steinar Bjørnstad (ITEM/Transpacket) - Steinar.Bjornstad@item.ntnu.no, Phone: 90081033,

Co-supervisor will be: Raimena Veisllari - veisllar@item.ntnu.no

26. (NT) Mobile-backhaul packet network properties and alternatives

This topic is suitable for 2-3 projects.

TransPacket is a startup-company targeting commercialisation of OpMiGua technology.

The “Optical Migration Capable Networks with Service Guarantees” (OpMiGua) concept (<http://www.opmigua.com>) has the main objective of combining the best properties from both circuit and packet switched networks into a hybrid solution. While the OpMiGua previously has been studied for large powerful transport networks with many wavelength channels, the main objective of this project is to find how the OpMiGua hybrid principle may be applied and how it will perform in a network containing only a few, or only a single channel.

Mobile-backhaul networks are moving from the use of circuit-switched technology towards using packet switched technology. Ethernet is brought out as the main candidate technology. Combining Ethernet and the OpMiGua principle may be an attractive solution by bringing the circuit switched properties of OpMiGua to Ethernet.

There may be several projects addressing different issues within the same main topic. The projects may typically involve the following topics and is suitable for being continued in a master:

- 1) How to transport synchronisation information across the packet based mobile-backhaul network. The student will study the properties of the alternatives in detail, including synchronous Ethernet and IEEE 1588.
- 2) QoS in mobile backhaul-networks. What level of QoS is required and how is this supported in an OpMiGua Ethernet mobile back-haul.
- 3) Characterizing the node and/or network performance through discrete-event simulation: An OpMiGua network being applied with a single or only a few channels (wavelengths).

The Master project will be tutored by:

Steinar Bjørnstad (ITEM/Transpacket) - Steinar.Bjornstad@item.ntnu.no, Phone: 90081033.

Co-supervisor will be: Raimena Veisllari - veisllar@item.ntnu.no

27. (IS) RAIN 1

Reserved to Anders Emil Salvesen

Supervisor: Martin Gilje Jaatun (Martin.G.Jaatun@sintef.no)

Professor: Danilo Gligoroski (danilog@item.ntnu.no)

28. (IS) RAIN 2

Reserved to Christian Askeland

Supervisor: Martin Gilje Jaatun (Martin.G.Jaatun@sintef.no)

Professor: Danilo Gligoroski (danilog@item.ntnu.no)

29. (IS) User Interface Design for Privacy Enhancing Technology

Protecting your privacy has become increasingly difficult, as more and more personal information is shared through the use of social networks, mobile applications and location based services. While there are some implementations of privacy enhancing technology to protect personal information, we have yet to see widespread adoption by end-users.

SINTEF ICT is currently investigating new approaches to privacy protection of end-users. We have implemented a prototype PET that aims to learn the user's privacy preferences and to help by giving users advice on how to behave in different privacy contexts. The software is intended to run on for example a laptop or smartphone. This project will design, implement and evaluate a user interface for the PET. Focus will be on end-user requirements, testing and usability.

The students will get the opportunity to work closely with researchers at SINTEF.

Supervisor: Karin Bernsmed Karin.Bernsmed@sintef.no/Åsmund Nyre, SINTEF ICT

Professor: Svein Johan Knapskog (svein.johan.knapskog@item.ntnu.no)

30. (IS) Using Case-based Reasoning for Privacy Decisions

Protecting your privacy has become increasingly difficult, as more and more personal information is shared through the use of social networks, mobile applications and location based services. While there are some implementations of privacy enhancing technology to protect personal information, we have yet to see widespread adoption by end-users.

SINTEF ICT is currently investigating new approaches to privacy protection of end-users. We have implemented a prototype PET that aims to help by giving users advice on how to behave in different privacy contexts. The software is intended to run on for example a laptop or smartphone. The software uses case-based reasoning (CBR) combined with anonymous community support to learn the user's privacy preferences. This project will propose, implement and evaluate the suitability of alternative CBR logic for the PET. Focus will be on modeling, programming and testing the behavior of different algorithms.

The students will get the opportunity to work closely with researchers at SINTEF.

Supervisor: Karin Bernsmed Karin.Bernsmed@sintef.no/Åsmund Nyre, SINTEF ICT
Professor: Svein Johan Knapskog (svein.johan.knapskog@item.ntnu.no)

31. (IS) Cloud computing security – OpenStack

In this project the student(s) will work with the OpenStack Cloud computing platform. The work will start with a literature study on security in Cloud computing. The student(s) will then

- Design and deploy a small-scale Cloud using OpenStack
- Investigate, analyze and evaluate the security of OpenStack Cloud implementations
- Propose a set of additional security mechanisms

The student(s) can do the practical work in the Cloud laboratory at SINTEF's premises in Trondheim.

Supervisor: Karin Bernsmed Karin.Bernsmed@sintef.no SINTEF ICT
Professor: Danilo Gligoroski (danilog@item.ntnu.no)

32. (IS) Senatus: Attacking and defending the Internet

Multiple students are accepted.

Intrusion detection is an important technique in computer network security. **Senatus** is a concept we recently propose in order to detect intrusions in a fashion of traffic classification and identification.

There are two main tasks:

1. Understand network attacks and their simulation tools then generate the attacks. Then simulate attacks in real backbone network, collect the data of the form Netflow/Qflow and prepare it to the analysis.
2. **Senatus** performance analysis investigation.

This project involves a direct collaboration with UNINETT.

Supervisor: Atef Abdelkefi (atef@q2s.ntnu.no), Arne Øslebø (arne.oslebo@uninett.no)
Professor Yuming Jiang (jiang@item.ntnu.no)

33. (IS) VizSec: Catch the attacker!

Note: Multiple students are accepted

Intrusion detection is an important technique in computer network security. VizSec is a recently developed tool for network attack detection and identification by visualization.

There are 2 main tasks:

1. Understand Vizsec: Vizsec is implemented in C, than the source code should be understood and tested.
2. Implement more detection techniques (entropy, histogram...) to validate the visually identified attacks

This project involves a direct collaboration with UNINETT.

Supervisor: Atef Abdelkefi (atef@q2s.ntnu.no), Arne Øslebø (arne.oslebo@uninett.no)

Professor Yuming Jiang (jiang@item.ntnu.no)

34. (IS) Implementation of Senatus : Hacker's fear

Multiple students are accepted

Intrusion detection is an important technique in computer network security. Senatus is a concept we recently propose in order to detect intrusions in a fashion of traffic classification.

The main task of this project is to implement Senatus in C/C++ or JAVA/J2EE and to validate it in real environment and network under real attacks. Given that the matlab code of **Senatus** exists.

This project involves a direct collaboration with UNINETT.

Supervisor: Atef Abdelkefi (atef@q2s.ntnu.no)

Professor Yuming Jiang (jiang@item.ntnu.no)

35. (NT) TDM lab : The Norwegian Troll, The Chinese Dragon and the New Zealander Maori are measuring the Internet

Multiple students are allowed to work on this project.

TDM lab is a project lunched by Norway, China and New-Zealand to measure the internet performance.

We are actually studying a new approach called TDM lab able based on the measurement between the three paths (Norway-China-Auckland) to automatically detect and identify different Internet states such as congestion, queuing building up and link failures within a general process called Internet anomography.

There are three main tasks:

1. Understand the measurement process
2. Process the collected data
3. Evaluate the performance of our proposed approach TDM-Lab.

This project involves a direct collaboration with UNINETT.

Supervisor: Atef Abdelkefi (atef@q2s.ntnu.no), Arne Øslebø arne.oslebo@uninett.no, Otto Wittner otto.wittner@uninett.no

Professor Yuming Jiang jiang@item.ntnu.no

36. (TS / NT) Telepresence Quality

Give a short reflected overview of perceived quality of existing telepresence systems, e. g., Tandberg/Cisco. Give a review of research on delays in telepresence/videoconferencing systems. Propose a test paradigm and necessary equipment for testing perceived quality of video and sound collaborations vs user2user delay caused by cameras, networks and codecs.

Apply the test paradigm to a case when the musicians and the conductor plays together over IP networks.

<http://www.item.ntnu.no/people/personalpages/fac/leifarne/collaborationspaces>

Supervisors: Otto Wittner, Uninett otto.wittner@uninett.no and Leif Arne Rønningen, Item

Professor: Leif Arne Rønningen (leifarne@item.ntnu.no)

37. (IS) Security - Internet compared with DMP

DMP's (Distributed Multimedia Plays) basic security philosophy is to reduce open-ness, take away responsibility from the user, give responsibility to the network- and service provider and apply a point-to-point security scheme as provided by IPsec. The task is to describe and evaluate security solutions of DMP and Internet services and applications, and make a comparison using formal methodologies.

http://www.item.ntnu.no/people/personalpages/fac/leifarne/the_dmp_architecture_specification_and_philosophy

<http://www.item.ntnu.no/people/personalpages/fac/leifarne/collaborationspaces>

Professor: Leif Arne Rønningen (leifarne@item.ntnu.no), Danilo Gligoroski (danilog@item.ntnu.no)

38. (TS,NT) Autostereoscopic Continuous-View Display

This assignment requires interest and some background in optics, lenses and displays. Existing state-of-the-art auto-stereoscopic multi-view displays (which we have in the lab) have several limitations. In the Collaboration Surface project we have proposed new display solutions which could enhance the quality of the displays substantially. The task is to design, build and test the new display concepts using up-scaled lens arrays and back projection from pico-projectors.

<http://www.item.ntnu.no/people/personalpages/fac/leifarne/collaborationspaces>

Professor: Leif Arne Rønningen (leifarne@item.ntnu.no)

39. (TS / NT) Test of the Quality Shaping Scheme applied to video traffic in Internet

Often when we stream video over the Internet the quality becomes unsatisfactory due to the variable transfer delay. Can the Quality Shaping Scheme solve this problem?

Tasks: Synthesize an HD video with three important moving objects and a static background object. Divide each object into nine sub-objects. Generate 36 packet streams with necessary parameters (use an AppTraNet subset), and send through various IP4 networks. Measure the variable delays of the packets. Drop packets that are delayed more than a T1 value, regenerate missing pixels by interpolation, and present on a PC screen. Assess the quality of the presented video for varying values of T1.

http://www.item.ntnu.no/people/personalpages/fac/leifarne/the_dmp_architecture_specification_and_philosophy

<http://www.item.ntnu.no/people/personalpages/fac/leifarne/collaborationspaces>

Professor: Leif Arne Rønningen (leifarne@item.ntnu.no)

40. (TS / NT) Image chain experimentation

In the project Collaboration Surfaces we have developed an advanced camera- and image processing system for extreme-quality multi-view imaging.

The intention of this assignment is to propose advanced Collaboration Spaces and scenes and run experiments with cameras distributed and posed in various ways in the space.

<http://www.item.ntnu.no/people/personalpages/fac/leifarne/collaborationspaces>

Professor: Leif Arne Rønningen (leifarne@item.ntnu.no)

41. (TS) A Discrete Event Simulation of Compression of Color Images by Network Using Windowed Kriging Interpolation

Abstract

Artistic elements in tele-immersive collaborations, such as collaborative percussions and dancing, depend on visual cues and thus require a maximal end-to-end delay for both audio and video data to ensure harmonious synchronization. With reported end-to-end delay as low as 11.5ms for good synchronization in such applications, current Internet standards are still unable to guarantee such extremely low delay for transmission of video data with graceful degradation of video quality. Addressing this issue, we propose the *compression-by-network* (CbN) approach based on the Distributed Multimedia Plays (DMP) architecture that enables network nodes to reduce video data intelligently due to changing traffic conditions. Figure 1 and Table 1 give an overview of the CbN approach and how it differs from the standard source coding approach with raw input digital signals. Our previous work have shown that windowed kriging interpolation is a promising compression technique suitable for CbN. The goal of this master's thesis is to further investigate this technique in CbN for color images by means of discrete event simulation. As the topic is novel, a publication at a good international conference is expected from this work, given positive results.

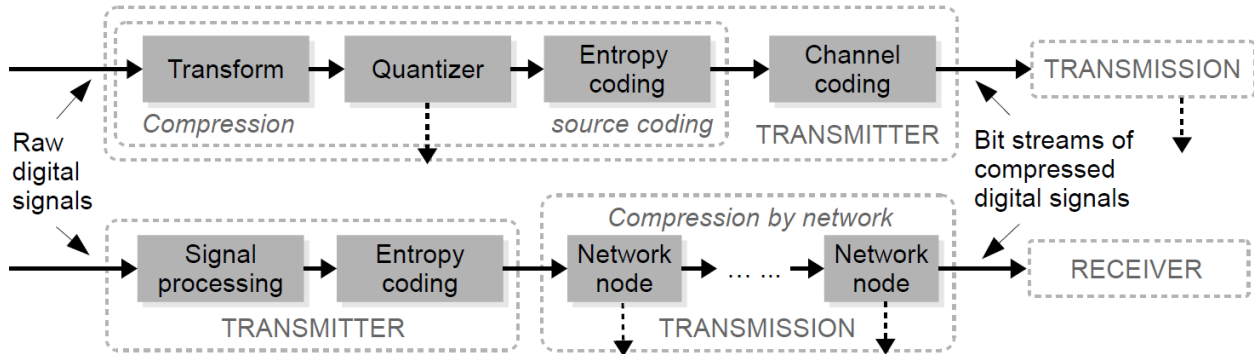

Figure 1. A comparative overview of standard source coding (top) and CbN (bottom) approaches in compressing digital signals. Arrows with dashed lines denote loss or reduction of information.

Table 1. Main differences between source coding and CbN approaches.

	Source coding	CbN
Data reduction source	Quantization	CbN
Data reduction location	Transmitter	Every network node and also transmitter
Guaranteed delay	No	Yes, designed for this
Network on quality	No control	Full control
Graceful quality degradation	Only by quantization. Lost packets cause nasty artifacts	Annoying artifacts minimized, given enough capacity.

Supervisor: Mauritz Panggabean (panggabean@item.ntnu.no)

Professor: Leif Arne Rønningen (leifarne@item.ntnu.no)

42. (TS) Android "Presence" app

The project is to develop a new "Contacts" application with GUI for Android. The goal is to synchronize and gather all available contacts and sort for availability "Presence" in different "VoIP" programs/protocols (for instance: Skype, SIP, GTalk etc.) The app should show a simple overview of contacts and how to connect using the various protocols or services. Some network and database programming is included.

See www.ideportalen.no and www.pixavi.com for more information.

Professor: Leif Arne Rønningen (leifarne@item.ntnu.no)

43. (TS) Android 3-D video capture

Android Gingerbread 2.3.4 only supports the use of one camera at a time. To render possible the use of 3D video and photography, lower levels of the Android framework needs to be changed and updated.

The assignment is to study the Android framework for camera handling and modify it. A possible solution is to program two cameras to behave like one camera with double horizontal resolution. Students will be given an Android device with two cameras, software source codes and HW documentation.

See www.ideportalen.no and www.pixavi.com for more information.

Professor: Leif Arne Rønningen (leifarne@item.ntnu.no)

44. (TS) Android collaboration app

Most Android-units allow the camera to share real time pictures and video over the supported networks. The assignment is to augment existing programs for video streaming and video conferencing with “collaboration” mechanisms and augmented reality.

Such collaboration mechanisms could be drawing on top of a video stream using a high definition capacitive touch screen. The mechanism could be an integral part of the encoder, or be drawn on top of the picture before being sent in a separate stream or protocol.

Other collaboration tools such as the implementation laser pointers onto the video screen might also be relevant

The student(s) will be given an Android device with an integrated laser pointer.

See www.ideportalen.no and www.pixavi.com for more information.

Professor: Leif Arne Rønningen (leifarne@item.ntnu.no)

45. (TS) Audio/Video QoS under Android

The project is to expand existing video calling software (VoIP) with fixed resolution and fixed bandwidth with QoS mechanisms.

Mechanisms such as:

- Adaptive estimation of available bandwidth
- Network delay/jitter
- Audio Feedback

that can be used to control and optimize the encoder.

Students will be given an Android device, software source codes and HW documentation.

Professor: Leif Arne Rønningen (leifarne@item.ntnu.no)

46. (TS) Composition of Situation-based Services

Project description: In this project, the student will investigate, design and implement a mechanism to support situated service composition in dynamic environments in which the characteristics of the surrounding environments and priority of services are frequently changing. Examples or scenarios, whose dynamic contexts include location, time, sensors and work-group, can be smart environments or emergency situations. Java programming is required.

Supervisor: Hien Nam Le (hiennam@item.ntnu.no)

Professor: Rolv Bræk (rolv.braek@item.ntnu.no)

47. (TS) Testing as a service for components

Project description: For component-based development approach, component testing is a challenging issue. In this project, the student will model, design and implement testing as a service (TaaS) to support the validation of developed components. UML modelling and Java programming are required. A simple railway control systems will be used to demonstrate the usefulness of TaaS.

Supervisor: Hien Nam Le (hiennam@item.ntnu.no)

Professor: Rolv Bræk (rolv.braek@item.ntnu.no)

48. (TS) Common Model for Passive Data Objects

Over the last years, a number of notations, standards and frameworks have become popular to describe, serialize and transmit object data. Amongst them are the Java Script Object Notation (JSON), Google Protocol Buffers, Facebook Thrift, but also the older XSOAP.

Most of them come with a definition language for the respective data formats. In this work, commonalities amongst these should be identified and a simple tool chain should be proposed and evaluated, so that a single data model can be used to use data consistently on different platforms using different transmission mechanisms.

Veileder: Frank Alexander Kraemer (frank.kraemer@item.ntnu.no)

Professor: Peter Herrmann (herrmann@item.ntnu.no) / Rolv Bræk (rolv.braek@item.ntnu.no)

49. (TS) Presence Application for Pixavi in Arctis

The project is to develop a new Contacts application for Android using Arctis. The goal is to synchronize and gather all contacts available and sort for availability presence in different VoIP programs/protocols (for instance: Skype, SIP, GTalk etc.) The application should show a simple overview of contacts and how to connect using the various protocols or services.

The projects will be conducted in close cooperation with experienced developers from Pixavi. The projects have a high priority and Pixavi will provide follow-up and feedback. The student will also

work with industrial designers from Kadabra Product Design during the development. Some travelling to Stavanger is expected. See also pixavi.com.

Supervisor: Frank Alexander Kraemer (NTNU/ITEM) frank.kraemer@item.ntnu.no, Harald Viste (Pixavi)

Professor: Peter Herrmann (herrmann@item.ntnu.no) / Rolv Bræk (rolv.braek@item.ntnu.no)

50. (TS) Voice Control for a Pixavi Application

This task is reserved for Erlend Gabrielsen.

Pixavi designs and develops mobile, wireless, high-definition video conferencing endpoints for use in industrial and hazardous areas. In this task it should be examined how the speech recognition capabilities of Android can be used in Arctis to control Pixavi's application.

The projects will be conducted in close cooperation with experienced developers from Pixavi. The projects have a high priority and Pixavi will provide follow-up and feedback. The student will also work with industrial designers from Kadabra Product Design during the development. Some travelling to Stavanger is expected. See also pixavi.com.

Supervisor: Frank Alexander Kraemer (NTNU/ITEM) frank.kraemer@item.ntnu.no, Harald Viste (Pixavi)

Professor: Peter Herrmann (herrmann@item.ntnu.no) / Rolv Bræk (rolv.braek@item.ntnu.no)

51. (TS) A model transformation framework for re-factoring Arctis building blocks

SPACE is the model-driven software engineering method developed in the Department of Telematics.

In SPACE and its tool set Arctis, the specification units are building blocks which are compositional pieces of UML activity diagrams, that enable to scale the system models. While the integration of building blocks to system models is usually done manually, graph transformation seems to be helpful in automizing this task for particular cases. For instance, one can use it to discover potential problems in a specification and to remedy the problem source automatically. The task for the student is to define cases for which graph transformation is useful in practice as well as to implement as least one case by creating and using the corresponding graph rewrite rules.

Programming work: there are some already exists codes for integrating the model transformation tool Henshin to Arctis, the student is required to finish this part of programming under Simon's full support with eclipse plug-in development.

Case study: we have proposed a rule-based approach for developing the artifacts that is reusable, composition in treating blocks.

The student are required to implement a pattern (the interrupt-able block pattern) and find some other patterns by himself or herself if possible.

Reference paper: Remedy of mixed-initiative in model based system development (unpublished) (ask Simon for a pre-print of the paper).

Supervisor: Simon Han (simon.han@item.ntnu.no)

Professor: Peter Herrmann (herrmann@item.ntnu.no) / Rolv Bræk (rolv.braek@item.ntnu.no)

52. (TS) Model transformation based specification decomposition and synthesis.

In department of Telematics, we developed a choreography models as a global view of service based specification. Now we have two levels of choreography models:

Flow global choreography models, flow localized choreography models. The first one is more abstract and complete. The later one is more detailed and compositional (Arctis building block is an implementation of flow localized chor-model).

and now we propose to provide an automatic mechanism for decomposition from the global choreography models to Arctis building blocks based on rule-based model transformation.

Programming work: Develop eclipse plug-ins for building a bridge between graph transformation framework Henshin and Arctis tool suit. We have some existing code for the development, the student is required to finish the programming work.

Case study: The student is required to extend the decomposition strategies from global models to localized models. The work can be done by extending existing work based on case study. The extension should be in depth analysis of choreography models, and to be able to transform some global choreography patterns to localized models.

Reference papers: Towards choreography model transformation by graph transformation.

Supervisor: Simon Han (simon.han@item.ntnu.no)

Professor: Peter Herrmann (herrmann@item.ntnu.no) / Rolv Bræk (rolv.braek@item.ntnu.no)

53. (TS/NT) Advanced Cloud Management

Cloud computing allows delivering and consuming Infrastructure as a Service (IaaS). Customers can access on-demand virtual machines and storage to deploy their software applications, and they can have these resources automatically scaled up or down depending on the system load. Being able to deploy applications on computing resources from different cloud providers, as well as scaling those resources based on application-specific parameters (i.e. not only on based on the system load) is desirable. Unfortunately, current solutions addressing these issues are non-existent or limited in their functionality.

In this project, the student should extend Claudia [1], an open-source cloud manager, to allow automatic deployment, configuration and scalability of applications in heterogeneous cloud

environments. This includes:

- Creating a GUI that allows describing the deployment and configuration of an application consisting of several components (e.g. a 3-tier application). The user should be able to choose among existing patterns (e.g. fault tolerance patterns)
- Extending Claudia's policy engine to support complex scalability rules

[1] <http://claudia.morfeo-project.org>

Supervisor: Humberto Castejón, Telenor ASA (humberto.castejon@telenor.com)

Professor: Peter Herrmann herrmann@item.ntnu.no

54. (NT) Service Deployment in Hybrid Clouds

The cloud deployment models are often characterized as private or public. A private cloud is used by one company only, while a public cloud offers resources and services to the general public.

The public cloud solution is more cost-effective than private clouds, but may fail to provide the required service level and security assurance. A hybrid cloud deployment model has therefore been proposed, e.g., using a combination of a private cloud and one or more public clouds. This model is also advantageous when the resources of the private cloud are exhausted.

A small cloud lab has been set up at Telenor Tyholt. This lab provides a private cloud infrastructure that can be extended to a hybrid cloud using e.g. Amazon Web Services.

This assignment should:

- * Identify and investigate possible techniques and policies for hybrid cloud deployment
- * Implement and test a selected set of policies by using Amazon Web Services or a another public cloud
- * Test the performance of the proposed solutions by implementing new scheduling functionality in existing cloud management software (e.g., OpenNebula or OpenStack)

Supervisor: Astrid Undheim astrid.undheim@telenor.com, Humberto Castejon

humberto.castejon@telenor.com, Telenor Group Industrial Development

Professor: Poul Heegaard (poul.heegaard@item.ntnu.no)

55. (NT) 4G and ITS–How to utilize LTE technology in ITS (intelligent Transport Systems) instrumentation

The aim is to study attractive ways to introduce LTE (new radio interface) technology and EPS ("the Evolved Packet Switching") system of the 4 G cellular systems into the new European ITS Communication Architecture. - The application area here is how to "link the vehicle with the transport infrastructure" (priority area IV EU ITS directive (Directive 2010/40/EU of 7 July 2010 of

the European Parliament). It may be of special interest to study how LTE based femtocells can be introduced to the ITS Communications Architecture. The last task is to identify and discuss interesting business roles for different stakeholders within this context (e.g. mobile service providers/mobile network operators, National Public Roads Administration, fibre plant owners/broadband service providers, etc.) - The scenarios to be studied are to be decided in cooperation with the supervisor:

Supervisor: Roy Ove Nilssen, Tjenestesjef mobildata, Netcom AS

Contact: Knut Evensen, Q-free AS (bidrar aktivt til ITS standardisering).

Professor: Steinar Andresen (steinara@item.ntnu.no)

56. (NT) Restructuring communication components for connecting vehicles

Intelligent Transport Systems (ITS) is the utilization of ICT in the transport sector. One important enabler for ITS is communication between vehicles and the infrastructure, which enables cooperation and information sharing between systems to provide safer, more efficient and more environmental-friendly services for road users. As defined by the European ITS Communication Architecture in ETSI, a mobile station deployed on a vehicle consists of a vehicle host that communicates through a mobile router and attached antennas in the same vehicle (e.g. as deployed and tested in the European CVIS project). This set-up involves a local vehicle network with wiring and powering.

The assignment is to look at this component architecture to see how it can be simplified to make the set-up more mobile between vehicles. One possible structure is to integrate the mobile router and antenna to give less in-vehicle wiring. The suggested component structure will be tested in the NTNU's ITS network laboratory in Elgesetergata.

Supervisor: Runar Sjøråsen

Professor: Steinar H Andresen (steinara@item.ntnu.no)

57. (NT) Future Rail Communication- LTE as an add on to GSM-R?

The Norwegian railroads has a GSM-R wireless communication system. This system is the carrier of railroad control messages used in ERTMS (European Rail Traffic Management System.) It also serves as an internal voice communication network for the railroad personel (for a more comprehensive introduction to GSM-R see e.g. <http://en.wikipedia.org/wiki/GSM-R>.)

The student shall study how LTE and (representing an IP high capacity network) can be “added” to the current GSM-R structure (among other thing by shared utilization of masts, power supply and backhaul communication resources). If time allows, the student also shall study how mobile operators like Telenor Mobile and Netcom could become “virtual operators” in such an infrastructure without compromising essential requirements of safety and security.

Supervisor: Ørjan Berg Johansen (Ikke avtalt)

Professor: Steinar Andresen (steinara@item.ntnu.no)

58. (NT) PRT in road tunnels?

Pedestrians and bicyclist very often are not catered for, when new long road tunnels over or under the sea are established. Links that previously could give passed by a pleasant ferry tour or a pleasant bicycle trip is changed into a car-only machine, and the passengers are directed to busses or taxi. In this project it is proposed to evaluate the possibility for using PRT (Private Rapid Transport) service through new tunnels. Such a "train" system, would need a track with a width of about 2 meter and a clearance in height of about 2,5 meter. In addition area that allows passengers to escape out of the "capsules" are needed. (Such area can be combined with escape routes for car travellers. To day, industrial solutions to PRT systems exist (see e.g. <http://vectusprrt.com/>) that can be applied—It is proposed to evaluate cost/benefit of a PRT system in tunnels, and also study how a PRT system can be include as a means of safety in the tunnels (e.g. to for transporting people and rescue personnel in closed capsules/cars.

Professor: Steinar Andresen (steinara@item.ntnu.no)

59. (NT) Integration with in-vehicle systems through the CAN bus

Intelligent Transport System (ITS) requires cooperation and information sharing between in-vehicle and roadside systems to increase safety and efficiency. Most operations in modern vehicles give signals that are available through the vehicle's CAN bus (e.g. air conditioning, braking, etc.), which is available for troubleshooting, etc.

The assignment will be to look at how such signals could be used in the design and implementation of ITS applications. This would include to get and interpret the CAN bus signals – something that would require the availability of a vehicle. Further, the assignment will involve the implementation of an application utilizing the CAN bus information and testing in real traffic environments.

Supervisor: Ola Martin Lykkja, Q-Free ASA

*Responsible: Adjunct Associate Professor Tor K. Moseng, NTNU ITEM
(tor.kjetil.moseng@item.ntnu.no)*

60. (NT) Predictability in IEEE 802.11 networks

Intelligent Transport Systems (ITS) is the utilization of ICT in the transport sector. One important enabler for ITS is communication between vehicles and the infrastructure, which enables cooperation and information sharing between different systems. The short-range communication is often based on the WiFi technology, i.e. the IEEE 802.11p standard, which is an amendment of the IEEE 802.11 for vehicular environments. However, this MAC (Media Access Control) protocol lacks predictability in delay and loss, which is especially important for time critical safety application in ITS (and other areas as well).

The assignment will look at different MAC solutions for how delay and packet losses are handled, especially when many users in a highly mobile environment are present. The MAC solutions will further be tested through simulations for different traffic models and users. If time allows, the solutions can be tested in the department's ITS network laboratory (NetLab).

Supervisor: Muhammad Qasim-Khan, NTNU ITEM

Co-supervisor: Jan Erik Håkegård, SINTEF

*Responsible: Adjunct Associate Professor Tor K. Moseng, NTNU ITEM
(tor.kjetil.moseng@item.ntnu.no)*

61. (NT) Vehicle Dropbox

Communication between vehicles and the infrastructure (e.g. through the use of short-range WiFi or long-range 2G/3G communication) enables cooperation and information sharing. Such Intelligent Transport Systems (ITS) is an important mean to increase the road safety and the traffic efficiency. Traffic related information is broadcasted to the vehicles, which is then given to the driver directly or through the navigation system. A more optimal scheme would be to allow the vehicles to download such information themselves – tailored information for the specific vehicles.

This assignment is to look into how traffic information may be tailored to specific individual vehicles by using the analogy from cloud based information storages like Dropbox. A digital copy of the vehicle, stored in “the cloud”, which includes e.g. the vehicle’s properties and whereabouts, is invoked by information providers that inserts relevant information for the targeted vehicle. The vehicle will then be able to ask its digital copy about any new information and update it at demand, which would not require a continuously connected vehicle. Relevant questions are how to invoke only targeted vehicles (e.g. only heavy goods vehicles or vehicles within a specific area) and how to restrict access to the digital copy.

The assignment includes a system design along with a prototype implementation of the proposed solution.

Supervisor: TBD

*Responsible: Adjunct Associate Professor Tor K. Moseng, NTNU ITEM
(tor.kjetil.moseng@item.ntnu.no)*

62. (IS) Security policies with Attributes, Rules and Role-based access control

Role-Based Access Control (RBAC) is a well-known security standard and a popular model for security policies. RBAC has been criticized for the difficulty of setting up an initial role structure, inflexibility in rapidly changing domains and inadequate support for dynamic attributes.

Recent interest in attribute-based access control (ABAC) and eXtensible Access Control Markup Language (XACML) suggests that attributes and rules could extend RBAC and make it more simple and flexible.

The main task: to create example security policies with attributes, rules and RBAC. The policies can be implemented in a logical form (in terms of rules) or in XML-based language - XACML.

(The example scenarios can be taken from UbiCompForAll project or can be your own.)

References:

[1] http://en.wikipedia.org/wiki/Role-based_access_control

[2] <http://en.wikipedia.org/wiki/XACML>

[3] <http://ubicompforall.org>

[4] D. Ferraiolo, R. Kuhn, R. Chandramouli. **Role-Based Access Control**. 2007. 338 p.

– The Book is available from me, as well as some useful articles to read. ☺

Supervisor: Sergiy Gladyshev, PhD student, sgladysh@item.ntnu.no

Professor: Peter Herrmann herrmann@item.ntnu.no / Svein Knapskog knapskog@q2s.ntnu.no

63. (IS) Trust and reputation policies for Social Networks

The topic is reserved for Carles Cardelús

Supervisor: Sergiy Gladyshev, PhD student, sgladysh@item.ntnu.no

Professor: Peter Herrmann herrmann@item.ntnu.no / Svein Knapskog knapskog@q2s.ntnu.no

64. (NT) Design av løsning for automatisk måleravlesning av strøm (AMS) basert på Wi-Fi

I løpet av 2016 skal alle norske husstander ha automatisk måleravlesning av strøm. Strømforbruket skal leses av automatisk hver time, i tillegg skal energileverandøren eller sluttbrukeren kunne spørre måleren i sanntid for å få et bilde av strømforbruket. Det krever en løsning med robust toveis kommunikasjon. 2/3 av alle hjem har trådløst bredbånd. Er det mulig å benytte eksisterende infrastruktur for AMS? Oppgaven skal gjøres WLAN som kommunikasjonskanal både teoretisk og ved å teste ut konseptet i praksis. Det er beregnet at det vil koste 10 milliarder å innføre AMS bare i Norge. Ved å bruke eksisterende infrastruktur tror vi det er mulig å redusere dette.

Gjennom oppgaven skal studenten sette seg inn i arkitektur for AMS, identifisere flaskehalsene og gjennomføre en større test av konseptet.

Veileder: Kjartan Mjøsund (kjartan@tradlosetrondheim.no) og Lars Kulseng, Trådløse Trondheim

Professor: Øivind Kure okure@item.ntnu.no

65. (TS/TSA) Utvikle Smartphone applikasjon for styring av smart-house teknologi

I løpet av 2016 skal alle norske husstander ha automatisk måleravlesning av strøm. Strømforbruket skal leses av automatisk hver time, i tillegg skal energileverandøren eller sluttbrukeren kunne spørre måleren i sanntid for å få et bilde av strømforbruket. For at brukeren skal få noe glede av AMS må det imidlertid utvikles produkter som gjør at brukeren kan bruke energien på en smartere måte. En måte å gjøre dette på er å innføre smart-house teknologi i hjemmet og la brukeren styre den fra mobiltelefonen.

Trådløse Trondheim jobber med en løsning hvor Wi-Fi skal brukes som bærer for AMS. Sammen med SIEMENS og flere energitilbydere skal Trådløse Trondheim utvikle en styringsapplikasjon for smart-house teknologi som skal testes ut i løpet av 2012. Ved å bruke applikasjonen skal brukeren kunne styre ulike strømkilder i hjemmet for å spare strøm og øke komforten.

Oppgaven består i å kartlegge hvilken informasjon en smart applikasjon bør presentere og utvikle ert grensesnitt som gjør at brukeren kan styre ulike enheter i hjemmet sitt via smarttelefonen. skal studenten sette seg inn i arkitektur for AMS, identifisere flaskehalser og gjennomføre en større test av konseptet.

*Veileder: Kjartan Mjøsund (kjartan@tradlosetrondheim.no) og Lars Kulseng, Trådløse Trondheim
Faglærer: Rolv Bræk (rolv.braek@item.ntnu.no)*

66. (TØ) Markedsundersøkelser for smart house teknologi / smartphone applikasjoner for styring av smart house teknologi

I løpet av 2016 skal alle norsk husstander ha automatisk måleravlesning av strøm. Strømforbruket skal leses av automatisk hver time, i tillegg skal energileverandøren eller sluttbrukeren kunne spørre måleren i sanntid for å få et bilde av strømforbruket. For at brukeren skal få noe glede av AMS må det imidlertid utvikles produkter som gjør at brukeren kan bruke energien på en smartere måte. En måte å gjøre dette på er å innføre smart-house teknologi i hjemmet og la brukeren styre den fra mobiltelefonen.

Trådløse Trondheim jobber med en løsning hvor Wi-Fi skal brukes som bærer for AMS. Sammen med SIEMENS og flere energitilbydere skal Trådløse Trondheim utvikle en styringsapplikasjon for smart-house teknologi som skal testes ut ila 2012. Ved å bruke applikasjonen skal brukeren kunne styre ulike strømkilder i hjemmet for å spare strøm og øke komforten.

Oppgaven består i å kartlegge markedspotensialet for smart house teknologi med fokus på smartphone applikasjoner for å styre ulike strømkilder i hjemmet. Hvor stor andel av husholdningene kunne tenke seg smart-house teknologi når AMS innføres i 2012? Og vil de bruke en applikasjon på smarttelefon for å kunne styre ulike energikilder i hjemmet?

*Veileder: Kjartan Mjøsund Trådløse Trondheim (kjartan@tradlosetrondheim.no)
Faglærer: Harald Øverby (haraldov@item.ntnu.no)*

67. (IS) Sikkerhet – Hvordan avdekke og forhindre tyveri av identitet eller sesjoner i trådløse nettverk?

Kriminalitet skjer i stadig større grad over nett og en viktig forutsetning for å bekjempe denne type kriminalitet er å kunne spore opp brukere. Et stort problem er at det per i dag er mulig å stjele og misbruke en brukers tilkobling, sesjon, ved bruk av trådløse nettverk. Hvordan kan vi avdekke sesjonstyveri og hvordan kan vi forhindre at det skjer?

*Veileder: Trådløse Trondheim v/Lars Kulseng
Faglærer: Stig Frode Mjøsnes (stig.mjolsnes@item.ntnu.no)*

68. (TS/TSA) Campusguiden – støtte av ulike typer events

Trådløse Trondheim utviklet en kartguide med innendørsposisjonering over Gløshaugen som ble lansert 31.08.2011. Applikasjonen er utviklet for smarttelefoner og skal tillate at brukeren søker etter rom, steder og ulike ressurser og vise vei til disse via detaljerte plantegninger og utendørs kart. Applikasjonen benytter brukerens posisjon for å vise ulike ressurser og vei til det brukeren søker. Se Campusguiden.no.

Campusguiden gjorde NTNU til verdens første universitet med innendørsnavigering og verdens største område med innendørsnavigering. Responsen etter lanseringen har vært veldig god og flere kunder både i Norge og internasjonalt har tatt kontakt. Trådløse Trondheim skal ilya det nærmeste året kommersialisere Campusguiden.

Trådløse Trondheim ønsker å utvide applikasjonen slik at applikasjonen støtter “events”. Et event kan være en liten happening på campus som “startpakke dagen” eller et profitt event som en konferanse med ulike stander og foredrag. Oppgaven skal kartlegge hvordan eventstøtte best kan presenteres og implementere en løsning som gjør at organisatorer av ulike events selv kan legge inn informasjon.

Veileder: Systemutvikler Gunnar Rangøy, Trådløse Trondheim
Faglærer: Rolv Bræk (rolv.braek@item.ntnu.no)

69. (TS) Campusguiden – hvordan kan brukeren selv komponere sin egen tjeneste

Trådløse Trondheim utviklet en kartguide med innendørsposisjonering over Gløshaugen som ble lansert 31.08.2011. Applikasjonen er utviklet for smarttelefoner og skal tillate at brukeren søker etter rom, steder og ulike ressurser og vise vei til disse via detaljerte plantegninger og utendørs kart. Applikasjonen benytter brukerens posisjon for å vise ulike ressurser og vei til det brukeren søker. Se Campusguiden.no.

Campusguiden gjorde NTNU til verdens første universitet med innendørsnavigering og verdens største område med innendørsnavigering. Responsen etter lanseringen har vært veldig god og flere kunder både i Norge og internasjonalt har tatt kontakt.

Det er mulig å integrere en rekke datakilder i Campusguiden, som timeplaner, hva som foregår hvor og belastning på data- eller lesesaler. I samarbeid med prosjektet UbiCompForAll skal studenten se på hvordan sluttbrukeren selv kan komponere og tilpasse sin tjeneste slik at brukeren kan skreddersy sin egen tjeneste.

Veileder: Systemutvikler Gunnar Rangøy, Trådløse Trondheim
Faglærer: Rolv Bræk (rolv.braek@item.ntnu.no)

Common header for the next 5 topics

UNINETT is a governmental controlled IP network operator in Norway. UNINETT provides universities, university colleges and research institutions with access to the global internet as well as access to a range of online services. UNINETT also offers counselling and act as secretary and coordinator in collaborative activities between the institutions interconnected by UNINETT.

70. (NT) Multicast capacity estimates for lecture IPTV in UNINETT

UNINETT has been running a pilot IPTV service based on multicast for some years. Many universities and university colleges are already making recordings of lectures, and it is expected that most institutions will record most lectures in the future.

The project's main objective is to investigate the possibility for UNINETT to allocate IPTV-channels (multicast addresses) for live broadcasting of ongoing lectures. How many concurrent lectures can UNINETT's backbone network support without degrading the general IP transport service? Modelling both user and lecture streaming behavior while taking UNINETT's topology and traffic load matrix into account, will be important parts of the project work.

Tutor: Otto J Wittner, UNINETT (otto.wittner@uninett.no)

Professor: Yuming Jiang (jiang@item.ntnu.no)

71. (NT) Multicast Receivers Estimation in UNINETT

UNINETT has a running pilot IPTV service based on multicast. When users listen in on (join) multicast streams only the closest edge-router in the overall multicast tree is notified. As only backbone transport services to institutions are provided, UNINETT has very limited access to such edge routers, hence there is no obvious means to in general measure how many user have joined multicast streams.

The project's objective is to investigate ways of combining data from multiple sources to estimate the number of viewer (join users) for a given multicast IPTV channel. Among potential information sources are unicast UNINETT's traffic matrix, web logs from the IPTV web portal and multicast tree data from the backbone routers.

Tutor: Otto J Wittner, UNINETT (otto.wittner@uninett.no)

Professor: Yuming Jiang (jiang@item.ntnu.no)

72. (NT) Quantifying UNINETT's high availability infrastructure

UNINETT is in the process of designing, developing and interconnecting infrastructure components with the aim to offer a foundation for application services of high availability. Redundancy and independence of the components have been ensured however so far no formal analysis quantifying the potential availability of component combinations have been performed.

The projects main objective will be to model a set of sample services and quantify their potential availability. If possible, a more general framework for analysis of future services should be purposed. Including factors in the models which quantify the difference between a test installation of a service and an operational installation are desirable. As UNINETT offers “best effort” services in general, a metric showing such a difference would be helpful to motive moving services from test to operational status.

Supervisor: Otto J Wittner (otto.wittner@uninett.no) Roger Skjetlein, Morten Knutsen, UNINETT

Professor: Bjarne Helvik (bjarne@q2s.ntnu.no)

73. (TS) End-User service composition framework and applications

The task is to further develop and enhance a framework and a set of applications for end-user service composition. The framework and the applications are handling value-added telecom services on Android devices.

The task will include the following sub tasks:

- Study of the end-user composition requirements based on a field study that has been conducted lately
- Propose improvements to the interaction mechanisms between end-users and the existing applications
- Implementation of these proposed improvements
- Study and implement a solution to integrate with service composition framework aimed for service providers (on behalf of end-users)
- Conduct testing and analysis of typical service scenarios from the daily life

Professor: Mazen Shiaa (malek@item.ntnu.no)

74. (IS) Application of Latin squares in cryptography

This research is to be assigned to 2 students.

A Latin square of order n is an $n \times n$ array containing n distinct symbols such that each symbol occurs exactly once in each row and each column. For instance, the popular Sudoku puzzles (in the standard version) are a special case of Latin squares of order 9, with additional restriction that 9 particular 3×3 adjacent subsquares must also contain the digits 1 to 9.

Latin squares are widely used in cryptography. Instances are known in design of ciphers, hashing functions, message authentication codes (MACs) and secret sharing schemes and so on. This research shall study the proposed Latin square based MACs and secret sharing schemes, compare them with schemes which are built on other primitives and the final aim is to propose new ones which maintain the advantages of using Latin squares but overcome the disadvantages in the known schemes.

Supervisor: Yanling Chen (yanling@item.ntnu.no)

Professor: Danilo Gligoroski (danilog@item.ntnu.no)

75. (IS) Science behind Sudoku: design an efficient algorithm to find critical sets of a Latin square

This research is to be assigned to 1 student.

A Latin square of order n is an $n \times n$ array, filled with n distinct symbols such that the same symbol never appears twice in the same row or column. A standard Sudoku is like an Latin square of order 9, with an additional requirement that its 9 particular 3×3 adjacent subsquares must contain the numbers 1 through 9.

We know that in a Soduko, sufficiently many numbers are given as clues in the initial grid to ensure that there is only one solution. Generally, the more numbers are given initially, the easier the puzzle becomes. Then the sets of clues which result in a unique solution are of our interest, in particular, those sets of minimal size (i.e., if any digit is deleted, then the remaining set can lead to more than one solution). In the terminology of Latin squares, such a set is called a critical set.

In this research, an algorithm should be designed in order to find the critical sets of a Latin square of a given order.

Supervisor: Yanling Chen (yanling@item.ntnu.no)

Professor: Danilo Gligoroski (danilog@item.ntnu.no)

76. (IS) Use of quasigroups in design of a check digital system

This research is to be assigned to 1 student.

Empirical investigations have shown that when transmitting a sequence of digits, the most common transmission errors made by human operators are single error ($a \rightarrow b$), adjacent transposition ($ab \rightarrow ba$), twin error ($aa \rightarrow bb$), jump transposition ($abc \rightarrow cba$), jump twin error ($aca \rightarrow bcb$) etc. The recognition of these errors is usually done by appending a check digit to a given sequence.

Using the binary operation in a quasigroup one can easily define a check equation which detects the single error easily. In order to detect all above mentioned errors, more conditions need to be addressed. The aim of this research work is to identify those conditions, find the quasigroups which fulfill those conditions and eventually establish a check digital system over them.

Some examples of a check digital system used in practice are: the European Article Number (EAN) Code, the Universal Product Code (UPC), the International Standard Book Number (ISBN) Code, the serial numbers of Euro banknotes and so on.

Supervisor: Yanling Chen (yanling@item.ntnu.no)

Professor: Danilo Gligoroski (danilog@item.ntnu.no)

77. (IS) Authentication: from password to biometric

This research is to be assigned to 2 students.

Nowadays portable devices such as smart phones are widely used. They often have access to Telecom networks and to the Internet. This make it possible to have an immediate access to many services such as voice mail or telephone banking anytime anywhere. Many of these services involve user authentication that currently done usually by using PIN or passwords.

Biometric systems have its great potential to be used for reliable user authentication. In particular, we note that most portable devices are equipped with a microphone and a video camera. So it is natural to combine with these functionalities to build a friendly and personalized authentication scheme based on face or voice recognition or both.

In this research work, a theoretical study of the biometric system shall be conducted in order to have insights into the possible information leakage on the sensitive personal data. Testing and evaluation of a real system are to be performed as well.

Supervisor: Yanling Chen (yanling@item.ntnu.no)

Professor: Danilo Gligoroski (danilog@item.ntnu.no)

78. (NT) Performance Dashboard for Adaptive Streaming

On-demand content delivery over Internet is growing in popularity, and Video services are now representing more than 50% of the total Internet traffic. Premium content providers are seeking to create sustainable business models in this area by using innovative streaming solutions. These solutions make the content delivery adapt to the varying network and end system conditions, and by this addressing the objective of achieving a high degree of QoE (Quality of Experience).

Technologies for implementing adaptive streaming require intelligence at application layer and are developed by different companies, some of which are: Microsoft's Smooth Streaming, Adobe's Dynamic Streaming, Apple's HTTP Live Streaming and Move Network's Adaptive Stream. In Norway we see that both TV2Sumo and also NRK are using the Microsoft solution.

The scope of the project is to use an already developed framework for event reporting from TV2Sumo clients, and develop a a performance analysis tool. This tool should use the aggregated event reports and present statistics for key QoS/QoE parameters and basic reports in order to help TV2Sumo even better understand the QoE of their provided services. The objective is to make a prototype of an "Adaptive Streaming Performance Dashboard".

References:

1.) Cisco CDN presentation -
http://tailieu.athena.edu.vn/Cisco/CISCO_LIVE_2010/BRKSPV-1101.pdf

2.) Microsoft's Smooth Streaming -

http://en.wikipedia.org/wiki/Microsoft_Silverlight

Supervisor: Bjørn J. Villa, PhD Candidate (bj@item.ntnu.no) Tor Einar Eriksen, Technical Product Manager, TV2

Professor: Poul E. Heegard (poul.heegaard@item.ntnu.no)

79. (TS) Implementing Session Initiation in Arctis

In [1] *Session Initiation as a Service* is described. These services are of a distributed reactive system that involve sessions among dynamically linked objects. The services are modeled in two steps: service structure is first modeled using UML 2 collaborations; thereafter service behavior is modeled as a choreography of collaboration uses representing sub-services using UML 2 activity diagrams.

The service session initiation can be generalized and separated from the session behavior. It can then be composed into complete composite services with dynamic session initiation. Different patterns of session initiation are proposed. The tasks of this assignment will be consisted of the following sub-tasks:

1. Investigating/improving the session initiation patterns.
2. Implementing the session initiation in Arctis.
3. If time allows, the student can investigate/propose further the solutions for composition of session initiation with service sessions.

[1] Fatima, U., Braek, R. and Castejón, H. N.: *Session Initiation as a Service*. In proceedings of the 15th international SDL Forum, Toulouse July 5-7 2011. LNCS volume 7083, Springer (2011).

Professor: Rolv Bræk (rolv.braek@item.ntnu.no)

Supervisor: Urooj Fatima (urooj@item.ntnu.no)

80. (IS) Copy-protection for new music service

This assignment is open for more than one student

Lavrentius AS (<http://www.lavrentius.no>) is planning a new online music service, where artists and publishers will be able to upload music and films to the music service web page. The media owners (publishers and/or artists) will receive payment when the media content is streamed or downloaded.

To prevent the intellectual property from unlawful exploitation, the media has to be protected by an appropriate copy-protection scheme. This assignment consists of:

1. Surveying and evaluating existing copy-protection mechanisms currently available
2. Determining whether existing solutions are appropriate for Lavrentius AS, and if necessary design a modified or alternative scheme
3. Implementing a prototype of the selected solution.

The assignment should be performed at NTNU, but with regular contacts with Lavrentius.

*Supervisor: Lornts Havstad lh@lavrentius.no Mobilephone +47 906 88 099
Professor: Danilo Gligoroski (danilog@item.ntnu.no)*

81. Web applications - New mobile service paradigm

Continue project – reserved to Phuc Huy Ngu

Professor: Do van Thanh

82. (IS) "Charm: A tool for rapid cryptographic prototyping"

Charm is a framework for rapidly prototyping advanced cryptosystems. Based on the Python language, it was designed from the ground up to minimize development time and code complexity while promoting the reuse of components. Charm uses a hybrid design: performance intensive mathematical operations are implemented in native C modules, while cryptosystems themselves are written in a readable, high-level language. Charm additionally provides a number of new components to facilitate the rapid development of new schemes and protocols.

The students will have to learn the principles of the Charm, (have or gain well understanding of the Python language), to install Charm and perform basic implementation for some crypto algorithm or protocol. Useful information from: <http://www.charm-crypto.com/Main.html> and <http://eprint.iacr.org/2011/617.pdf>

This assignment is open for 2 students.

Professor: Danilo Gligoroski (danilog@item.ntnu.no)

83. (IS) "Cryptol"

Cryptol is a domain-specific language (DSL) and tool suite that simplifies the specification of a cryptographic algorithm. Cryptol is currently used by the Intelligence Community (IC) and was designed by Galois for the NSA as a public standard for specifying cryptographic algorithms. A Cryptol reference specification can serve as the formal documentation for a cryptographic module, eliminating the need for separate and voluminous English descriptions. Cryptol is fully executable, allowing designers to experiment with their programs incrementally as their designs evolve. Cryptol compilers can generate C, C++, and Haskell software implementations, and VHDL or Verilog HDL hardware implementations.

The students will have to learn the principles of the Cryptol, to install Cryptol and perform basic implementation for some crypto algorithm or protocol. Useful information from: <http://corp.galois.com/cryptol/>

This assignment is open for 2 students.

Professor: Danilo Gligoroski (danilog@item.ntnu.no)

84. (TS) Product line variability in service systems.

Product line engineering and service engineering are two important disciplines of systems engineering that traditionally have been kept separate. The purpose of this assignment is to investigate how they may be combined. Product line engineering has focus on variability and how to effectively produce systems instances having the properties desired by a particular customer. Service engineering has focus on services and how to generate service providing systems. This study shall concentrate on service models expressed using UML collaborations and activities, and variability expressed using feature diagrams and/or variability languages. It shall investigate how these approaches may be combined to model a crisis management system as a case study. The same system has been used in the Comparing Modeling Approaches workshop and will therefore enable a comparison with other approaches modeling the same system.

Professor: Rolv Bræk (rolv.braek@item.ntnu.no)

85. (TS) Implementing Session Initiation in Arctis

In [1] *Session Initiation as a Service* is described. These services are of a distributed reactive system that involve sessions among dynamically linked objects. The services are modeled in two steps: service structure is first modeled using UML 2 collaborations; thereafter service behavior is modeled as a choreography of collaboration uses representing sub-services using UML 2 activity diagrams. The service session initiation can be generalized and separated from the session behavior. It can then be composed into complete composite services with dynamic session initiation. Different patterns of session initiation are proposed. The tasks of this assignment will be consisted of the following sub-tasks:

1. Investigating/improving the session initiation patterns.
2. Implementing the session initiation in Arctis.
3. If time allows, the student can investigate/propose further the solutions for composition of session initiation with service sessions.

[1] Fatima, U., Braek, R. and Castejón, H. N.: *Session Initiation as a Service*. In proceedings of the 15th international SDL Forum, Toulouse July 5-7 2011. LNCS volume 7083, Springer (2011).

Professor: Rolv Bræk (rolv.braek@item.ntnu.no)

Supervisor: Urooj Fatima (urooj@item.ntnu.no)

86. (TS) Treasure Hunt Components

The Treasure Hunt is a collaborative game for Android developed here at the institute. In this thesis, additional components and services for the game should be developed and integrated.

Supervisor: Urooj Fatima (urooj@item.ntnu.no), Frank Alexander Kraemer (frank.kraemer@item.ntnu.no)

Professor: Rolv Bræk (rolv.braek@item.ntnu.no)